

## **Installation Instructions For Reversed Hub Design.**

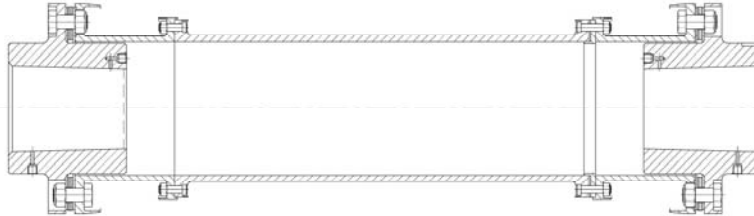

### **1. General Notes**

Any Warranty furnished by **Euroflex**, either expressed or implied, shall be, null and void, if any component of the Coupling of whatever kind, including nuts, bolts, washers, etc., not supplied, specified or agreed by **Euroflex**, is used in the Coupling assembly, OR any modification is made to any component of the Coupling, without express approval of **Euroflex**.

For general safety, alignment and maintenance instructions see relevant sections of this document.

### **2. Important**

All tightening bolts/nuts and screws should be done evenly (cylinder head fashion) to 50% & then 100% of the stated torque. Threads should be lubricated with Molybdenum Disulphide grease or equivalent.

### **3. Installation Instructions**

**Important note**– The main coupling bolts & nuts are tightened by **Euroflex** and need not be disturbed for installation. Under normal circumstances these should NOT BE TOUCHED since this may affect the balance of the unit.

- a) Dismantle the Spacer #2 and shims by removing attachment bolt and nuts.
- b) Position the driving and driven machinery and check the Distance between shaft ends and Record this distance (reference this as dimension L) [The +/- is the variation that can be accommodated by the axial adjustment shims. A more accurate initial alignment will assist if the rotor has to be changed in the future].
- c) Check the alignment of the shafts is within the limits defined in the alignment section of this document.

PREPARED	CHECKED	APPROVED	DATE
SRIKANTH	GS RAJU	KVMR	13/10/2012

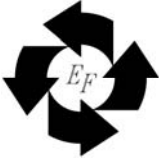

- d) Calculate the number of Axial Adjustment Shims that will be required during the installation of the coupling.
- e) Install the Hub assemblies on the respective equipment shafts.
- f) Insert the required quantity of Axial Adjustment Shims, into the extended register on the spacer flange ensuring holes line up.
- g) Both ends of the coupling may have been shipped with the Gagging Screws & Bushes fitted over the Element Assemblies. At this point remove the screws & bushes, store the bushes for future use and refit the screws.
- h) Tighten the Gagging Screws at both ends of the coupling to compress each Element Assembly.
- i) Install the Spacer#2 in between spacers#1, ensuring that the interface register seats correctly. Assemble to the Spacer #1 & spacer #2, joints by using the Attachment Bolts & Nuts, ensuring threads are correctly lubricated, and Torque Tighten (Cylinder Head Fashion) to the value shown on the drawing. If this is not possible ensure that both machine shafts are pushed hard back and, if necessary, tighten the Gagging Screws a little more in both sections of the couplings to further compress the Element Assemblies.
- j) REMOVE ALL Gagging Screws from BOTH ENDS of the Coupling and store for future use. As the screws are removed the compression of the Element Assemblies will be relieved and the adjacent flanges of Spacer #1 & 2 will move together. It is important to ensure that as this happens the registers locate correctly.
- k) Fit the Attachment Bolts & Nuts to connect the remaining flanges of Spacer #1 and spacer#2 and Torque Tighten (Cylinder Head Fashion) to the value shown on the drawing, ensuring that the threads are correctly lubricated. Care will have to be when tightening these nuts to make sure that the registers are drawn together correctly.
- l) Fully tightened the attachment bolts and nuts up to rated torque shown in the drawing.
- m) Please refer coupling assembly drawing for tightening torque values of Attachment bolts & nuts.

#### **4. Removal Instructions**

Coupling removal is a reverse of the above installation procedure.

PREPARED	CHECKED	APPROVED	DATE
SRIKANTH	GS RAJU	KVMR	13/10/2012

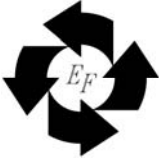

**INSTALLATION INSTRUCTION DIAGRAMS**

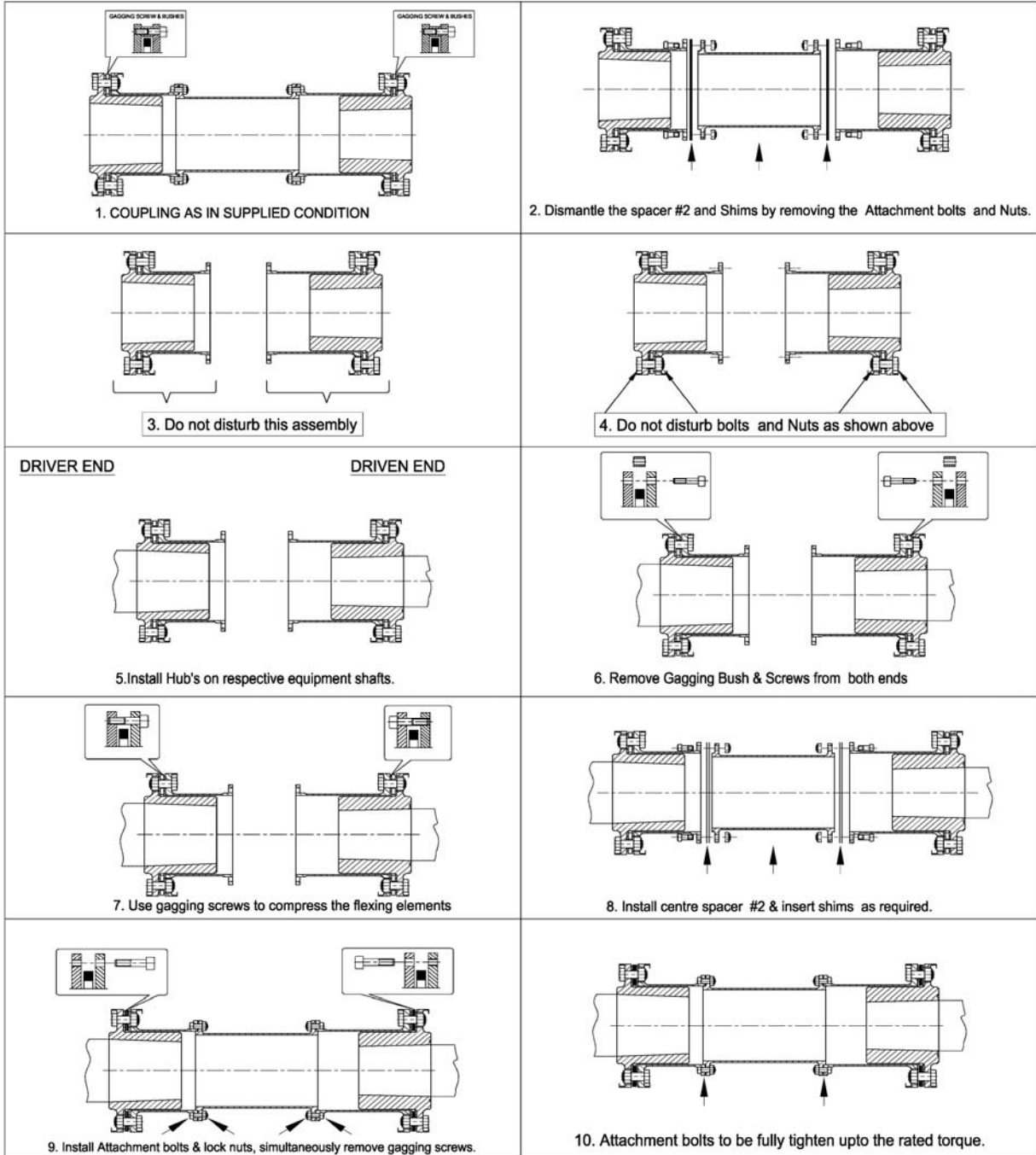

PREPARED	CHECKED	APPROVED	DATE
SRIKANTH	GS RAJU	KVMR	13/10/2012